

—PAILUNG



—PAILUNG

Rib-Transfer Electronic
Jacquard Circular Knitting Machine

PAI LUNG MACHINERY MILL CO.,LTD.
No.8 Ding Ping Rd., Ruel-Fang Industrial Park, Ruel-Fang Dist., New Taipei City, Taiwan
台灣新北市瑞芳區瑞芳工業區頂坪路8號
TEL:886-2-24978888 FAX:886-2-24965666
www.pailung.com.tw

Knitel Series

Double Knit

Rib-Transfer Electronic Jacquard
Circular Knitting Machine

羅紋上下移圈電腦緹花圓筒針織機 PL-KRTDCJ

THE FABRIC OF INNOVATION

Products Introduction

PL-KRTDCJ

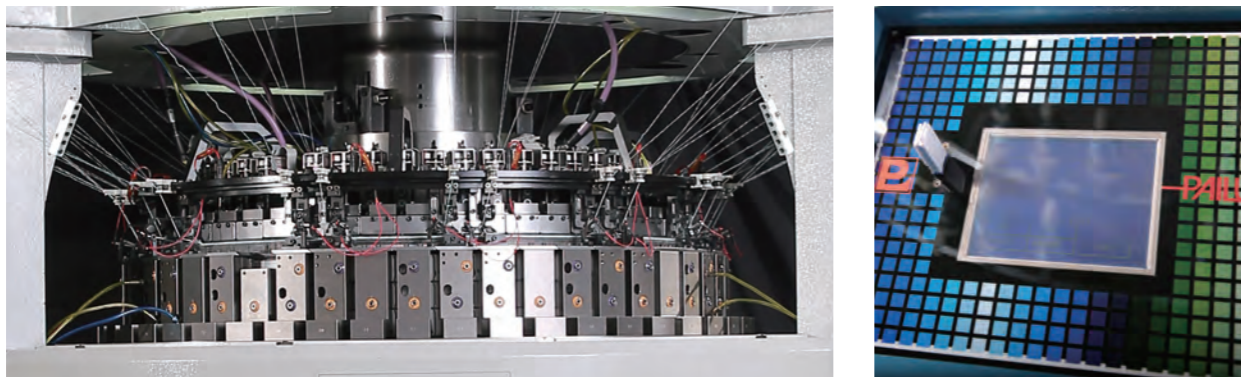

PL-KRTDCJ is a prominent model with the latest technology and refinement. Its design philosophy is uncompromising and brings together practical application, making a double jersey full jacquard knitting machine great with that unique Pai Lung spirit.

In response to knitting shoe upper market demand, Pai Lung not only provides the flat knitting machine solution, but also provides the circular knitting technology in shoe upper knitting.

Its function includes rib, rib mesh transferred either from dial to cylinder or from cylinder to dial, electrical stitch adjustment.

This machine is based on every 3 feeders as 1 unit. Including knitting feeder, cylinder loop transferred to dial and the dial loop transferred to cylinder. Every 3 feeders become a complete knitting unit. For example, if the machine specification is 34" x 48 Feeders, which means 24 feeders are

knitting feeders and 24 feeders are rib transferred feeders.

From the efforts on computerized knitting machines, you may find out Pai Lung' strong mind in realizing the ideal. This attitude is revealed from the excellent performance of machines as well. You choose Pai Lung, Pai Lung develops your infinite future. That is why we advance.

Diameter	Feeder No.	Gauge
34"	48F	12G,14G
36"	48F	12G,14G
38"	52F	12G,14G
40"	52F	12G,14G

產品介紹

PL-KRTDCJ

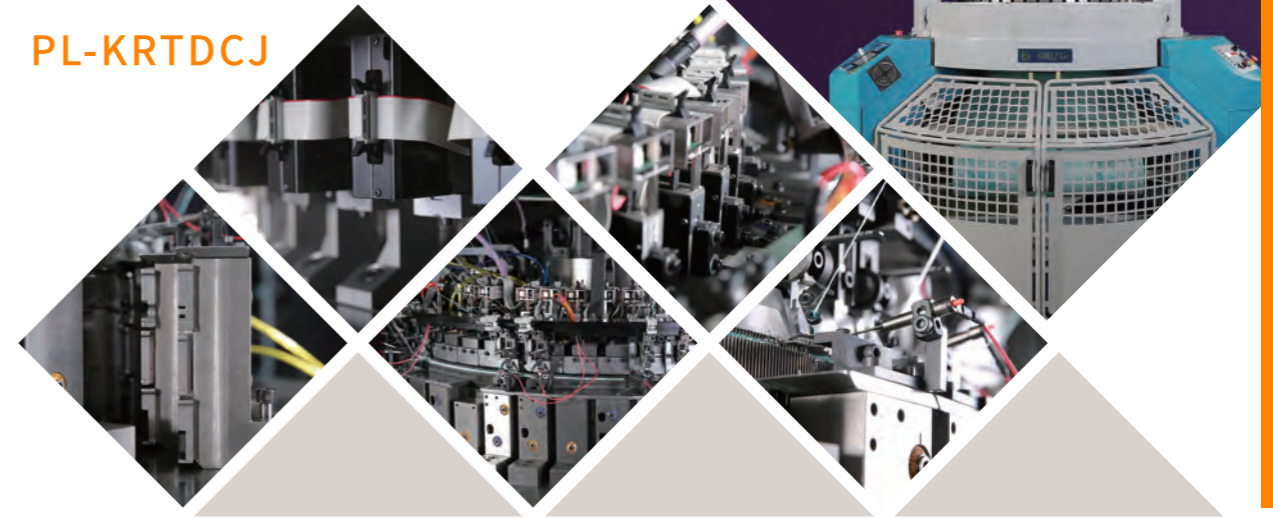

來自於針織的熱誠，對於雙面羅紋上下移圈電子提花機的運用，佰龍公司永不懈怠地自我升級，其發展已有目共睹。專注於本業發展的精神，持續累積業界實際操作經驗，奠定了對此機型運用面上堅強實力。

因應針織鞋面市場的快速崛起，佰龍除了提供橫編電腦針織機的解決方案，更創新開發圓編領域的新世代機種KRTDCJ，結合電子選針大提花、上下移圈、及電子變更度目功能的多功能複合機因而產生，可織造具有鞋型的鞋面織樣，及網狀效果的織紋等鞋面特殊效果。

機台的原始配置為每 3 口(包括織造口、下圈上移、上圈下移)為一完整編織單位；以此機台規格 34" x48F 為例，就是 24 口織造、24 口移圈；亦可搭配增減織造口比例作變化。

該機型可織造雙面提花與移圈提花布種，還可以編織特殊變化組織、正反目組織及贅肉布。

從佰龍對電腦機種上的努力，您可以看見我們挑戰理想的毅力，在運轉中綻放卓然超群的性能。您選擇佰龍，佰龍則為您發展了未來。



尺寸	口數	針距
34"	48F	12G,14G
36"	48F	12G,14G
38"	52F	12G,14G
40"	52F	12G,14G

■ Applications 鞋面織造應用



■ Dimensions 機器外觀尺寸圖

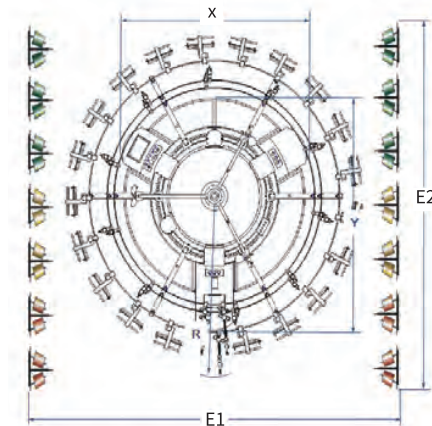
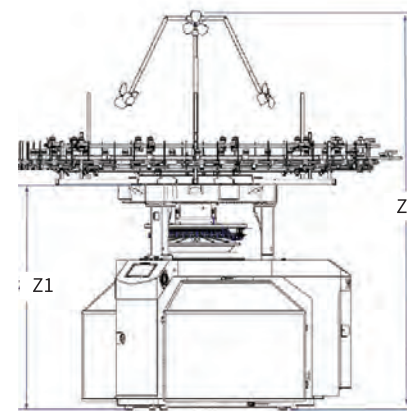

TF	X	Y	R	Z1	Z2	E1	E2
31"~34"	2035	2370	1682	2005	3457	3564	3345
35"~40"	2177	2531	1762	2005	3457	3724	4060











- (mm)
- Above specification may be changed without notice.
 - Investigating management software does not include factory layout.
 - 以上規格配備若有變更, 無法先行通知, 仍以實體為準。
 - 客戶需自行購買配合整廠管理所需之配線。

■ Productivity Info 產能資訊

Diameter	Feeder No.	Gauge	RPM	Shoe-upper Per Day(Pair)
34"	48	14	10	1080
34"	48	14	15	1612
38"	52	14	10	1170

- This information would be affected by yarn and other conditions, please refer to the actual situation.
- 此產能數據會受到紗線規格和織造組織等因素影響, 此為參考數據, 請以實際為準。

■ **Specificstions**
技術規格

	Standard	Options
Control 	<ul style="list-style-type: none"> - Digital control panel • 3 shift counter, rpm, fabric roll per-set, & working hr. • Stop reason indication. • Emergency & control buttons 	<ul style="list-style-type: none"> - Integrated LCD touch control panel • Full info & control present • Ready for POMS • Ready for Decotex
Power 	<ul style="list-style-type: none"> - 380V, 50/60Hz, - 5.5Kw/7.5Hp - 7.3Kw/10Hp - Inverter power control 	<ul style="list-style-type: none"> - 220V, 50/60Hz - 415~460V, 50/60Hz
Take - up 	<ul style="list-style-type: none"> - Motor take up system - Cadratex fabric spreader - Standard fabric roll dia” 17” 	<ul style="list-style-type: none"> - Pai Lung mechanical take up system - Folding/rolling take up system - Open width take up system - Yung Leader mechanical take up system
Needle 	<ul style="list-style-type: none"> - Needle and pattern jacks in dial - Needles, middle jack, pattern jack in cylinder 	
Camming 	<ul style="list-style-type: none"> - Jacquard camming selection in dial and cylinder 	<ul style="list-style-type: none"> - Dial Swing Cam - Cylinder Swing Cam
Yarn storage 	<ul style="list-style-type: none"> - Zirconium yarn carrier 	<ul style="list-style-type: none"> - Spandex attachment
Frame 	<ul style="list-style-type: none"> - Pai Lung T frame - Oil-bathed wire bearing system - Count-clockwise direction 	
Yarn carries 	<ul style="list-style-type: none"> - Zirconium yarn carrier 	<ul style="list-style-type: none"> - Spandex attachment
Oiler 	<ul style="list-style-type: none"> - Uniwave misty oiler 	<ul style="list-style-type: none"> - Pulsonic 5.2 pressure oiler - Pai Lung misty oiler
Creels 	<ul style="list-style-type: none"> - Striper Side Creel 	<ul style="list-style-type: none"> - D8/D9 type PVC or aluminum tube creels - Overhead creels - Fan creels - Filter creels
Others 	<ul style="list-style-type: none"> - Needle detectors - Lighting on frame & fabrics - Top fans system - Dial height & horizontal level gauges - Min compressed air : 6 bar, 250 l/min 	<ul style="list-style-type: none"> - Uniwave central anti-dust blow system - Memminger top fan system - Integrated LCD control system can be added: • POMS on-line monitoring
Knitting Setting	<ul style="list-style-type: none"> - 24 F Knitting+12F Transfer from cylinder to dial+12F Transfer from dial to cylinder - Transfer ratio can be changed 	

	標準配備	選項配備
控制介面 	<ul style="list-style-type: none"> - 數據顯示控制面板 • 三班制工作計數, 機台轉速, 布量預控設定 • 異常停機原因顯示 • 一般操作及緊急停止按鈕 	<ul style="list-style-type: none"> - 整合式觸控功能液晶螢幕 • 完整提供所有操作狀況及數據顯示 • RS-485 介面可結合監控系統POMS • Decotex 連接埠
電源 	<ul style="list-style-type: none"> - 380V, 50/60 Hz - 5.5Kw/7.5Hp - 7.3Kw/10Hp - 變頻傳動控制裝置 	<ul style="list-style-type: none"> - 220V, 50/60Hz - 415~460V, 50/60Hz
捲布裝置 	<ul style="list-style-type: none"> - 馬達式捲布機 - 標準捲布直徑 17” - 均衡張力方形撐布架裝置 	<ul style="list-style-type: none"> - 佰龍機械式變速捲布機 - 摺布/捲布兩用捲取機 - 泳立機械式變速捲布機
織針 	<ul style="list-style-type: none"> - 上針盤織針、提花針 - 針筒織針、中段挺針、提花針 	
三角配置 	<ul style="list-style-type: none"> - 上針盤為提花系統三角配備 - 下針筒為提花系統三角配備 	<ul style="list-style-type: none"> - 上針盤活動三角(成圈,浮線,浮花) - 下針筒活動三角(成圈,集圈,浮線,浮花)
儲紗裝置 	<ul style="list-style-type: none"> - 電子儲存式送紗器 SFE 	<ul style="list-style-type: none"> - 氨輪輸紗器 MER3 - 依客戶需求提供其他形式儲紗裝置
機架 	<ul style="list-style-type: none"> - 佰龍 K 系列機架 - 浸油潤滑四鋼線軸承 - 逆時鐘轉向運轉下布 	
喂紗嘴 	<ul style="list-style-type: none"> - 氧化鋅紗嘴 	<ul style="list-style-type: none"> - 氨綸添紗裝置 - 包紗管相關設備
噴油機 	<ul style="list-style-type: none"> - Uniwave 噴霧式噴油機 	<ul style="list-style-type: none"> - Pulsonic 5.2 脈衝式壓力噴油機 - 佰龍噴霧式噴油機
紗架 	<ul style="list-style-type: none"> - 採用四面開放式彩條紗架 	<ul style="list-style-type: none"> - D8/D9 組合式 PVC 風管或鋁管落地紗架 - 頂蓬式紗架 - 風扇除絮型風扇紗架 - 密閉式過濾紗架系統
其他 	<ul style="list-style-type: none"> - 壞針或布面破洞自停裝置 - 機架及布面照明裝置 - 上段風扇吹絮裝置 - 針盤高度及水平分度規 - 壓縮空氣最低需求: 6 bar, 250 l min 	<ul style="list-style-type: none"> - UNIWAVE 中段噴風除塵設備 - 美名格上段除塵 - 整合式液晶螢幕觸控螢幕可連結以下裝置: • POMS 佰龍線上監控系統
提花系統	<ul style="list-style-type: none"> - 針盤提花採用雙功位壓變陶瓷選針系統 - 針筒提花採用三功位壓變陶瓷選針系統 	<ul style="list-style-type: none"> - Pandora 繪圖軟體
織造	<ul style="list-style-type: none"> - 24口編織+12口下移上+12口上移下 移圈比例可搭配 	