

SPECIFICATION

Gauge	14G
Knitting Width	36" (91cm)
Carriage/System	Single carriage three systems.
Knitting Function	Knit, Tuck, Miss and simultaneous Transfer, front or back, regardless of carriage direction.
Knittable Pattern	Double Jacquard, horizontal and vertical floating yarn effect, eyelet, shaping, intarsia(2 colors on both side)
Needle Selection	Full-Jacquard needle selection by solenoid system.
Stitch Density	Stitch density controlled by stepping motors with adjustable levels which can be stored in 99 levels.
Knitting Speed	Max 1.0m/sec. knitting speed varies according to gauge and knitting conditions. Variably adjustable speed levels. 16 additional programmable speeds.
Racking System.	Servo motor with ball screw racking system. Max4-inch racking left and right side each. 1/2 and 1/4 pitch also available from any position. 8 programmable speeds.
Sinker System	3-segment plating sinker.
Transmission System	Belt driven transmission system via AC servo motor.
Yarn Cutter and Grippers System	2 set of one yarn cutter and two grippers.
Yarn Carriers	16 carriers
Trail	4 trails
Side Tension	16 units on both sides.
Top Tension	24 units.
Aux. feeder	2 pieces on both sides. (optional)
Covers	Full safety cover for protecting user and dust-proofing.
Emergency Stop	One emergency stop buttons on left.
Auto-Stop	Break yarn, knot yarn, yarn tension changes, needle broken, fabric drop, fabric rewind, improper position of racking, improper position of carriage, and programming error, etc will automatically stop the machine.
3 Colors Warming Lights	Green light- Normal operations. Yellow light- Fabric take down completed.
Setup Combs System	256 levels takedown combs with special setup needles.
Takedown System	Main roller and sub roller. 256 level of adjustable tensions and controlled by program to open and close.
Language	Language available in Traditional Chinese and English. Other language is potential.
Data Input	USB 2.0
Design software	Pai Lung "Kniteditor" .
UPS	Power supply for resuming knitting after power failure.
Power input	One-phase AC power 220V±10%, 50-60 Hz.
Electronic Yarn Feeder	Two MSF-3 at each side, total are 4 MSF-3 electronic yarn feeders.

Options:

- Plating yarn carrier.
- Intarsia carriers and kit.
- Base on particular fabric design, MSF-3 electronic yarn feeder could be added in as options

※Above equipment maybe changed without notice.



Single Carriage Three System
Float Plating Shoe-upper Computerized
Flat Knitting Machine

PAI LUNG MACHINERY MILL CO.,LTD.
No.8 Ding Ping Rd., Ruel-Fang Industrial Park, Ruel-Fang Dist., New Taipei City, Taiwan
台灣新北市瑞芳區瑞芳工業區頂坪路8號
TEL:886-2-24978888 FAX:886-2-24965666
www.pailung.com.tw

PAILUNG

Fabric
Innovation



Series

Single Carriage Three System
Float Plating Computerized
Flat Knitting Machine

單機頭三系統系列浮線鍍圈鞋面電腦橫編針織機 PLF-IFP093

Pai Lung I-series
Flat knitting Machine

ShupperKnit is our perfect technology producing shoe upper. The IFP-093 is a very unique model of this series, which provides woven-like structure, intarsia technique, and diverse patterns on shoe upper.

ShupperKnit是佰龍為您提供最完美的鞋面織造科技，而IFP-093則是其中非凡獨具的機種，能織造類梭織的結構，嵌花的鞋面變化，亦可提供豐富變化的鞋面組織。

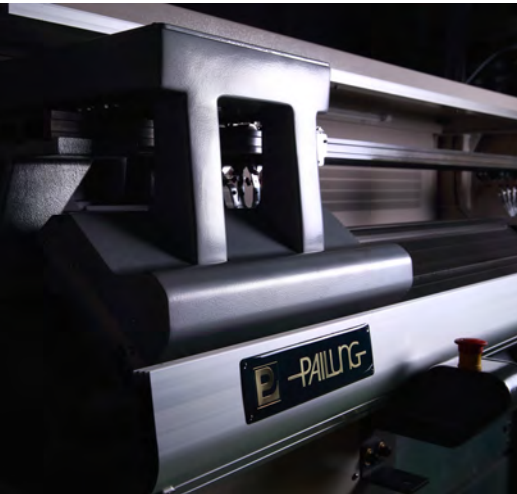

Application 產品應用



Dimensions 機器外觀尺寸圖

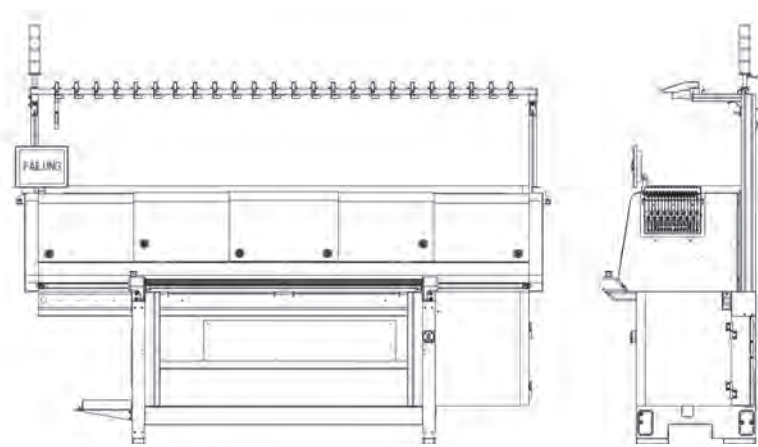

" L x W x H (mm) 2478 x 880 x 2336 Net weight/毛重 850 kg

Productivity Info 產能資訊

Shapping or Not	Productivity (Per day)
Yes	24 pairs
No	36 pairs

● This information would be affected by yarn and other conditions, please refer to the actual situation.
● 此產能數據會受到紗線規格和織造組織等因素影響，此為參考數據，請以實際為準
100% Polyester 600D(40 D Spandex)



Float Plating Shoe Upper Sample

Pai Lung I-series
Flat knitting Machine

技術規格

針距範圍	14G
織造寬度	36 英寸(91cm)
機頭系統	單機頭三系統設計。
編織功能	除一般織/吊目/不織/移環翻針等，可同時前床翻後床及後床翻前床，不受機頭方向限制。
應用組織	浮線鑲圈+雙面提花效果(袋編)、浮線橫向與縱向編織效果、挑洞，收針成型、INTARSIA-(左2色，右兩色)
編織密度(度目)	線圈密度由步進馬達所控制，具備256段可編程度目值，左右系統獨立。
編織速度	最高1.0米/秒，編織速度因針速和編織條件而有不同。多段可調節速度，並具備8段可編程序速度。
搖床	採高轉速伺服馬達搭配精密滾珠螺桿傳動，在左右各4英寸範圍內之搖床位移皆由程式控制，可於針床任何位置搖1/2針和1/4針並具備個別微調位移之功能。
沉降片	三段式鑲圈沉降片
傳動方式	皮帶傳動，交流電伺服馬達、不需加油。
自動夾切紗組	左右邊各一組。一組紗剪組內包括兩支紗夾與一支紗剪。
紗嘴	兩側各8支紗嘴，總共16支，便於在任何位置切換。
導軌	配置4支導軌。
多段可調式過紗架	左右兩側16支設計。
上段張力天線	24個張力天線。
送紗裝置	左右側各1組。
密閉式工作空間	全機覆蓋以保護人員並兼防塵及減低噪音。
緊急自鎖開關	機台具備1只，遇緊急可立即按下停車鈕，切斷電源。
自停裝置	斷紗，紗結，紗線張力改變，斷針，落布，倒捲，撞針，搖床異位，機頭異位，程式錯誤等皆會使機台設備自動停止。
三色操作警示燈	以不同燈色顯示機台狀態。
起底板裝置	256段拉力控制起底板配合複合起底扣針。
捲布系統	256段拉力控制主/副羅拉，全自動打開和關合。
系統顯示	無按鍵設計，採12.1"觸碰式彩色背光液晶面板，具1024 X 768高解析度，人因工程介面設計，畫面操作簡單易懂。
語言種類	中文/英文，可直接切換。亦可提供其它語系。
花型輸入	可使用USB 2.0
軟件	佰龍專用"Kniteditor"。
不斷電系統(UPS)	在突然停電時，提供備用電源完成該行運作後停止，待電復繼以完成該片。
規格	單相交流 220V±10%，50~60 Hz。
電子儲紗器	兩邊各2支MSF3電子儲紗器
選針系統	壓電式八段選針系統

選配:

- 疊紗紗嘴。
- 電子儲紗器可依織造設計另加選購
- 引塔置設備。

※以上規格配備若有變更否，無法先行通知，仍以實體為準