

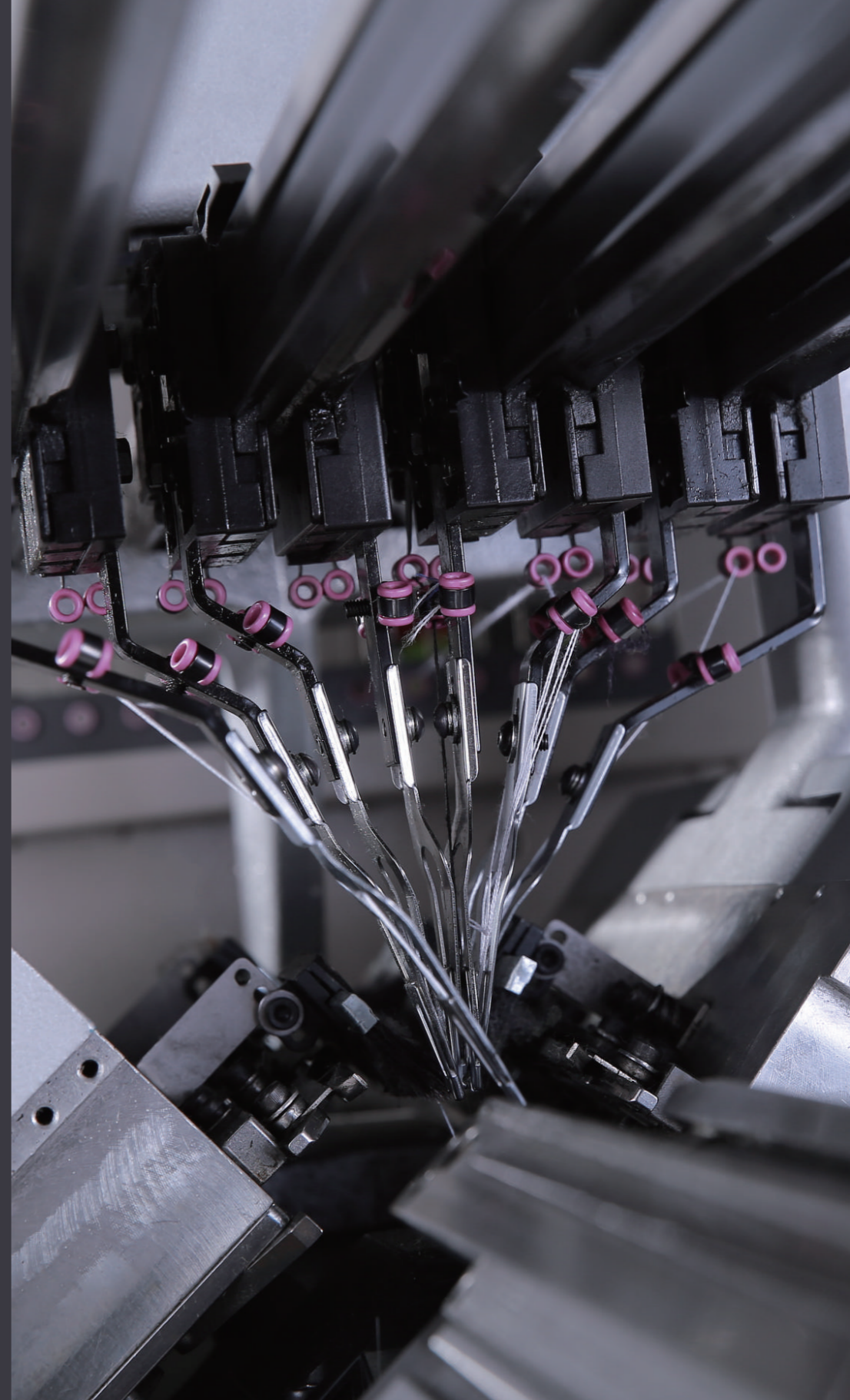

Single Carriage Two System
Computerized Flat Knitting Machine

PAI LUNG MACHINERY MILL CO., LTD.
No.8 Ding Ping Rd., Ruei-Fang Industrial Park, Ruei-Fang Dist., New Taipei City, Taiwan
台灣新北市瑞芳區瑞芳工業區頂坪路8號
TEL:886-2-24978888 FAX:886-2-24965666
www.pailung.com.tw

PAI LUNG
THE FABRIC
OF INNOVATION



Series

Single Carriage Two System
Computerized Flat Knitting Machine

單機頭雙系統系列電腦橫編針織機

PLF-IS132

Product Introduction



Unceasing innovation is our natural responsibility. We realize customer's request and know how to make machine better. Our flat knitting machine "I" series is born to reach the best performance with high speed and fabric success.

Three different working lengths are available for customer demands in our one carriage with two system computerized flat knitting machine series. Full knitting functions are ready including second stitch and split needle function. A new Piezo needle selection system is in adoption for high speed efficiency. Machine needle gauge range is supplied from 5G to 16G, and with the gauge simulation in certain gauges which can be more flexible in manufacture and pattern enrichment.

To effectively control various yarn feeding affection, a friction type of auxiliary feeder is the only standard, and new electronic yarn rate feeder is ready for optional device for more accurate quality control. Machine is with standard sub roller and main rollers system; the later takedown device with multi-level control by programming and anti rolling ability for particular design work. Both sides are installed cutter and gripper units collaborated with combing setup system for helping yarns saving and easier production.

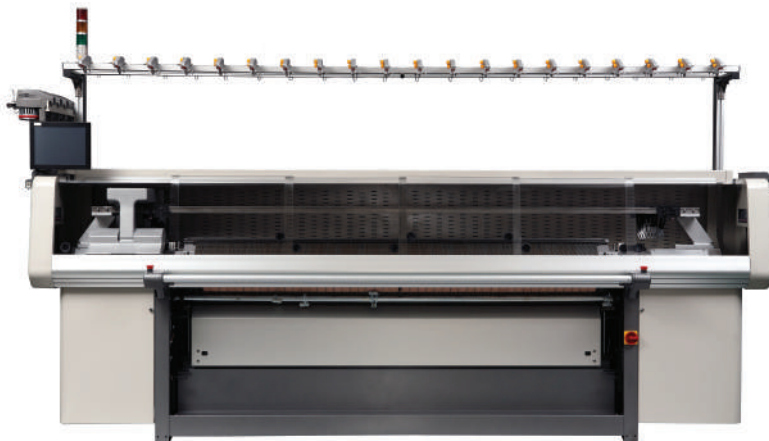

We believe customization and unique application will be the flat knit future. Closed cooperation and continues innovation based on our high efficient flat knitting machine is the solution that we are preparing for clients' tomorrow business.

不斷進化是我們對產品持續發展的負責精神。為了更貼近使用者的需求，努力在每一片織布織造上，力求速度與成功率表現極致。作為佰龍的標準，我們的電腦橫編機“I”系列正是成就客戶需求的最佳生產設備。

佰龍單機頭雙系統電腦橫編機，依據工作區需求長度可提供45”、52”、80”不同規格。機頭具備完整織造功能，包含兩段度目及分針。搭配革新技術的陶瓷選針系統，使用者能明確的感受高速的生產效率。在針距的規格上，除了5至16針的針距範圍，亦可依需求在特定範圍內，提供跨針距功能之各式織針，使織物的變化更加豐富多元。

著重紗線喂入時各種影響因素，除了配備實用摩擦式輔助裝置外，亦可依據需求選配電子主動式送紗率控制組，有效提升織品品質。標準主副羅拉設計，具備多段微調，程式開合控制及主羅拉反轉功能，除配合不同織物需求，特殊織造上亦可配合。左右兩側標準式夾切紗組及起底板裝置，對於紗線節省及生產上助益良多。面對橫編織品用途及服飾流行趨勢不斷創新，我們可依客戶不同的需求而持續創新進化。精益求精，滿足需求，正是佰龍橫編機的發展理念。



產品 介紹

PLF-
IS132 52”
IS202 80”
IS112 45”



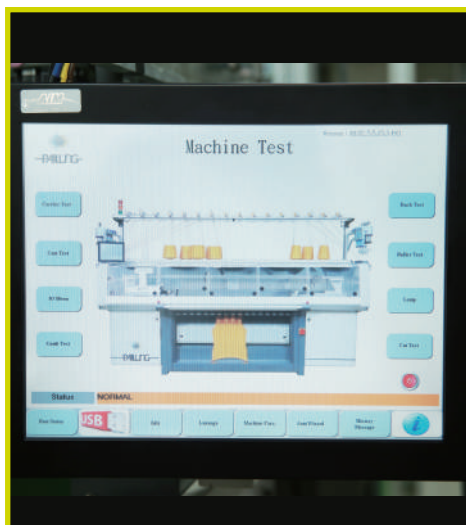

1. Intuitive Human- Machine interface & Advanced Control system

Equipped with a large 12.1 inch color LCD touch panel, 1024x768 high resolutions, all machines' statuses are graphically displayed, integrated all control needs in simple operating functions for easy to learn and understand. The USB port is on the back of the panel.

直覺式人機操作介面 & 先進的控制系統

採用12.1英寸超大畫面觸碰式背光全彩液晶螢幕，除了機台運轉狀況一目瞭然外，更可在1024X768高解析度下，可直接於螢幕上編輯編織程式為特色，控制器整合所有控制需求於簡易操作功能中，能完整顯示編織時的參數。檔案存取以USB方式輸入。存取槽在螢幕背面。



2. Automatic Yarn cutter and Gripper Device

Automatic yarn cutter and gripper device work together with setup comb in continuous production and it can also cut unnecessary yarns to avoid waste.

自動夾切紗裝置

夾切紗裝置可將編織過程中，與衣片相連接、但暫時不用的紗線剪斷，避免浪費紗線。

3. Automatic Setup comb

Set yarn is hooked in comb needles to prevent traditional weighting and yarn lost. Unique setting needle design can make sure the setting action easy. Cooperated with yarn cutter and gripper device, it can increase speed of knitting processes.

自動起底板

特殊扣針式起底針設計，確保自動起底功能正常，起底紗不脫鉤，加快編織速度。搭配夾切紗模組，可單片獨立編織，大幅減少前後衣片間的廢紗量。進而達到節省紗線成本及縮短編織時間，增加產量。

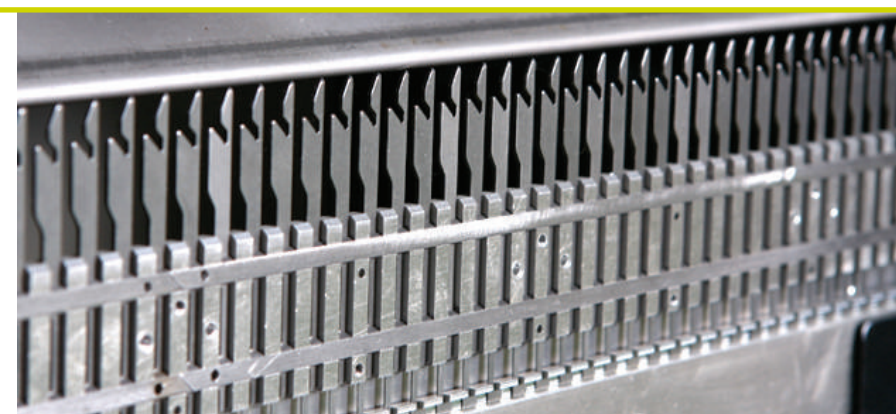

4. Piezo-electronic Actuators

New design for better needle selection and performance. The selecting plate numbers depends on gauge design.

陶瓷撥片選針系統

新型設計以提升選針效率及使用上穩定度。撥片數量依據不同針距需求。



5. New piezo- electronic actuators

New piezoelectronic actuators- for better needle selection and performance.

主副羅拉系統

主羅拉系統具備多段張力調控功能，並可於織造中打開關合及反轉以便利特殊織造需求。副羅拉裝置運用不但利於協助下布，也能夠對引返組織織造時降低變形影響。



6. Aux. feeder

It is easier for yarn tension control and can improve knitted fabric quality and working efficiency.

側邊輔助送紗裝置

讓操作者更方便調整喂入紗線張力，有效提高衣片的品質與編織速度。



7. Yarn carriers

Thinner sized carrier for easy adjustment and yarn feeding. Even able for plating work.

紗嘴設計

本機採用適形薄片紗嘴，精巧易於調整，適於各式紗線織造，及疊紗需求運用。



Options 選配



Electronic storage feeder

An electronic storage feeders as optional device which can deals with irregular yarn feeding for more accurate yarn tension in quality control.

電子儲紗器

此電子控制儲紗裝置可依需求而提供，針對張力穩定及提升布面品質有極佳之效果。

Intarsia Carriers and kits

For intarsia purpose can be changed to special intarsia carriers and relative system.

引塔夏紗嘴裝置

在某些圖案需求需運用引塔夏紗嘴，可依選配裝置增加。

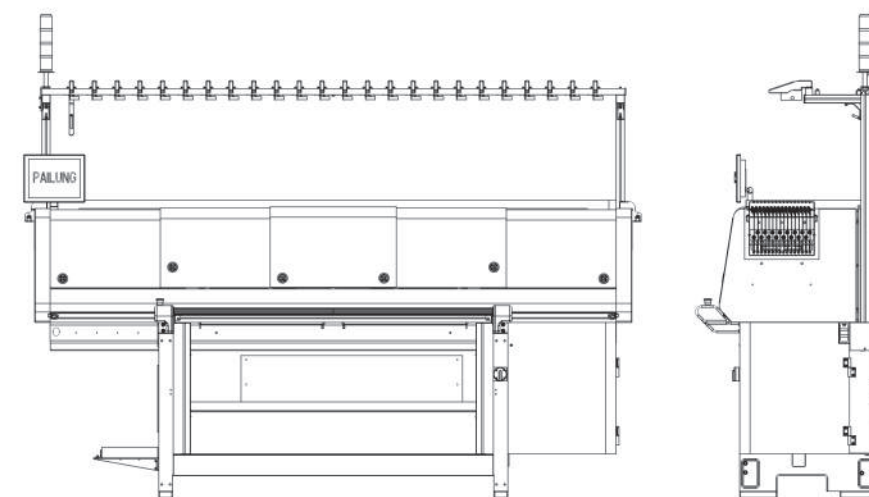

PLF-IS112	45" L x W x H (mm)	2550x 880 x2000	Net weight/毛重 850 kg
PLF-IS132	52" L x W x H (mm)	2730x 880 x2000	Net weight/毛重 950 kg
PLF-IS202	80" L x W x H (mm)	3550x 880 x2000	Net weight/毛重 1100 kg

Specifications

Pai Lung I-series Flat knitting Machine

針距範圍	5G、7G、10G、12G、14G、16G及部分可變針距功能。
織造寬度	45英吋(114cm)、52英吋(132cm)、80英吋(203cm)。
機頭系統	單機頭雙系統設計。
編織功能	除一般織/吊目/不織/移環翻針等，可同時前床翻後床及後床翻前床，不受機頭方向限制。
應用組織	絞花/正反目/挑孔/成型織片/選色提花/贅肉組織等。
選針系統	特殊壓電陶瓷撥片作動多段選針。
編織密度(度目)	線圈密度由步進馬達所控制，具備256段可編程度目值，左右系統獨立。
編織速度	最高1.3米/秒，編織速度因針速和編織條件而有不同。多段可調節速度，並具備16段可編程序速度。
搖床	採高轉速伺服馬達搭配精密滾珠螺桿傳動，在左右各1英吋範圍內之搖床位皆由程式控制，可於針床任何位置搖1/2針和1/4針並具備個別微調位移之功能。
沉降片	活動式沉降片。
傳動方式	正時皮帶配合同服馬達往復運作。
自動夾切紗組	左右邊各一組。一組紗剪組內包括兩支紗夾與一支紗剪。
紗嘴	兩側各8支紗嘴，總共16支，便於在任何位置切換。
導軌	配置4支導軌。
多段可調式過紗架	左右兩側16支設計。
上段張力天線	16個張力天線。
送紗裝置	左右側各1組。
密閉式工作空間	全機覆蓋以保護人員並兼防塵及減低噪音。
緊急自鎖開關	機台具備1只，遇緊急可立即按下停車鈕，切斷電源。
自停裝置	斷紗，紗結，紗線張力改變，斷針，落布，倒捲，撞針，搖床異位，機頭異位，程式錯誤等皆會使機台設備自動停止。
三色操作警示燈	以不同燈色顯示機台狀態。
起底板裝置	操作簡易，不易起底失敗，配合夾切紗模組，加快生產速度，具備32段可編程起抵拉力值。
捲布系統	羅拉多段電腦控制，全自動打開和關合，具備32段可編程捲布拉力值。
系統顯示	無按鍵設計，採12.1"觸碰式彩色背光液晶面板，具1024 X 768高解析度，人因工程介面設計，畫面操作簡單易懂。
語言種類	中文/英文，可直接切換。亦可提供其它語系。
花型輸入	可使用USB 2.0
軟件	佰龍專用"Kniteditor"。
不斷電系統(UPS)	在突然停電時，提供備用電源完成該行運作後停止，待電復織以完成該片。
規格	單相交流 220V±10%，50~60 Hz。

選配：

- 疊紗紗嘴。
- 引塔夏設備。

※以上規格配備若有變更否，無法先行通知，仍以實體為準

Gauge	5G, 7G, 10G, 12G, 14G, 16G and gauge simulation.
Knitting Width	45" (114cm) 、52" (132cm) 、80" (203cm).
Carriage/System	Single carriage double systems.
Knitting Function	Knit, Tuck, Miss and simultaneous Transfer, front or back, regardless of carriage direction.
Knittable Pattern	Cable, Links-Links, Lace, Shaping, Color Jacquard, Bourrelete.
Needle Selection	Full-Jacquard needle selection by Piezo system.
Stitch Density	Stitch density controlled by stepping motors with adjustable levels which can be stored in 256 levels.
Knitting Speed	Max 1.3m/sec. knitting speed varies according to gauge and knitting conditions. Variably adjustable speed levels which can be stored in 16 speed groups.
Racking System.	Servo motor with ball screw racking system. Max 1-inch racking left and right side each. 1/2 and 1/4 pitch also available from any position.
Sinker System	Movable sinker.
Transmission System	Belt driven transmission system via AC servo motor.
Yarn Cutter and Grippers System	2 set of one yarn cutter and two grippers.
Yarn Carriers	
Trail	4 trails
Side Tension	16 units on both sides.
Top Tension	16 units.
Aux. feeder	2 pieces on both sides.
Covers	Full safety cover for protecting user and dust-proofing.
Emergency Stop	One emergency stop buttons on left.
Auto-Stop	Break yarn, knot yarn, yarn tension changes, needle broken, fabric drop, fabric rewind, improper position of racking, improper position of carriage, and programming error, etc will automatically stop the machine.
3 Colors Warning Lights	Green light- Normal operations. Yellow light- Fabric take down completed.
Setup Combs System	Setup Comb with special setup needles. Setup tensions are stored in 32 tension groups.
Takedown System	Main roller and sub roller. 256 level of adjustable tensions and controlled by program to open and close.
Language	Language available in Traditional Chinese and English. Other language is potential.
Data Input	USB 2.0
Design software	Pai Lung "Kniteditor" .
UPS	Power supply for resuming knitting after power failure.
Power input	One-phase AC power 220V±10%, 50~60 Hz.

Options:

- Plating yarn carrier.
- Intarisa carriers and kit.

※Above equipment maybe changed without notice.